

SMP 7 ECO 230

GENERAL INFORMATION	
Max flow rate	30 m ³ /h / 132 gpm
UVC transmittance	97%- 1 cm
UV dose	600 J/m ² (Dose for combined chlorine reduction)
Water Temperature range	5-50° C
Total consumption	600 W
Mounting	Horizontal or Vertical (with lamp working in horizontal)

UV REACTOR	
Material	Stainless Steel 316L
Connections	3" threaded GAS (other on request)
Drain	1/2" GAS thread
Max working pressure	10 bar / 145 PSI
Protection class (with automatic cleaning system)	IP65 / NEMA 4x IP54 / NEMA 12
Shape	Cross Flow
Flow direction	Both directions
Quartz sleeve cleaning system: Manual Wiper Automatic Wiper	Standard (on request)

UV LAMP	
Number	1
Lifespan	10000 hrs
Type	Medium pressure lamps type

UV SENSOR	
Type	UVC selective sensor type MP1128S
Sensor Cable	Shielded cable 10 meters
Body Sensor material	Stainless steel 316L

CONTROL PANEL	
LCD ² (PLUS)	
Material and colour	Painted Steel – RAL 7035 (plastic or SS on request)
Dimensions	See drawing
Protection class	IP 54 / UL NEMA 12 (other on request)
Ambient temperature range	5 – 45 °C
Rel. humidity	20-95% non-condensing (condensing on request)
Power supply	230 V - 50/60 Hz (other on request)
Lamp cable	6 m
Monitor display	LCD ² SITA
Hour meter	Yes for total system life
Resettable hour meter	Yes for lamp life control
Lamp function control	Yes
Alarm led	Yes
Free contact (NO - NC)	Yes – general alarm (max 2 A)
230 V output (NO - NC)	Yes – general alarm (max 2 A)
Remote ON/OFF contact	Yes (settable)
ON/OFF Timer	Yes (settable)
Reactor temperature measurement and alarm	Yes (°C) – settable value (shut off for high temperature)
UV Irradiance measurement and alarm	Yes (% or W/m ² optional) – settable value
4/20 mA output	Optional – for Irradiance and water temperature
Audio alarm	Optional

Rev.12/22

NOTE:
 - THESE OVERALL DIMENSIONS CAN CHANGE A LITTLE BECAUSE OF THE CONSTRUCTIVE TOLERANCES AND THE ASSEMBLING OF MECHANICAL COMPONENTS YOU USED.

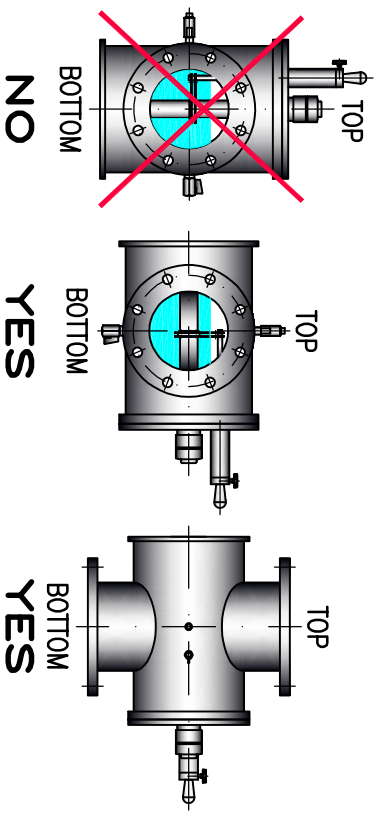
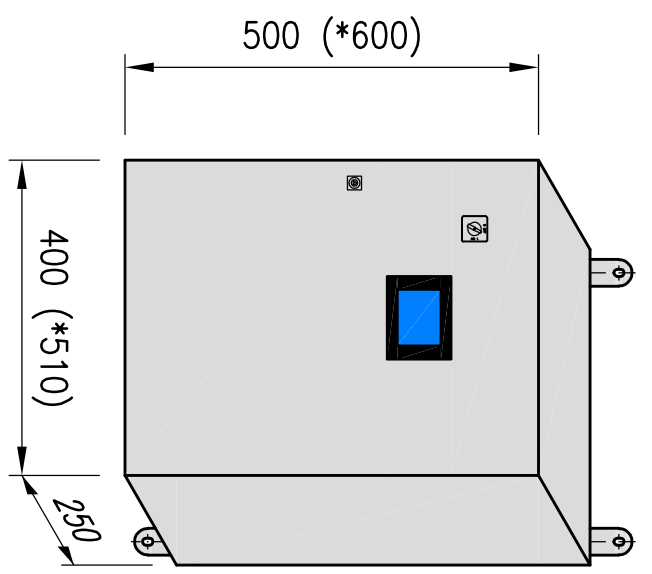
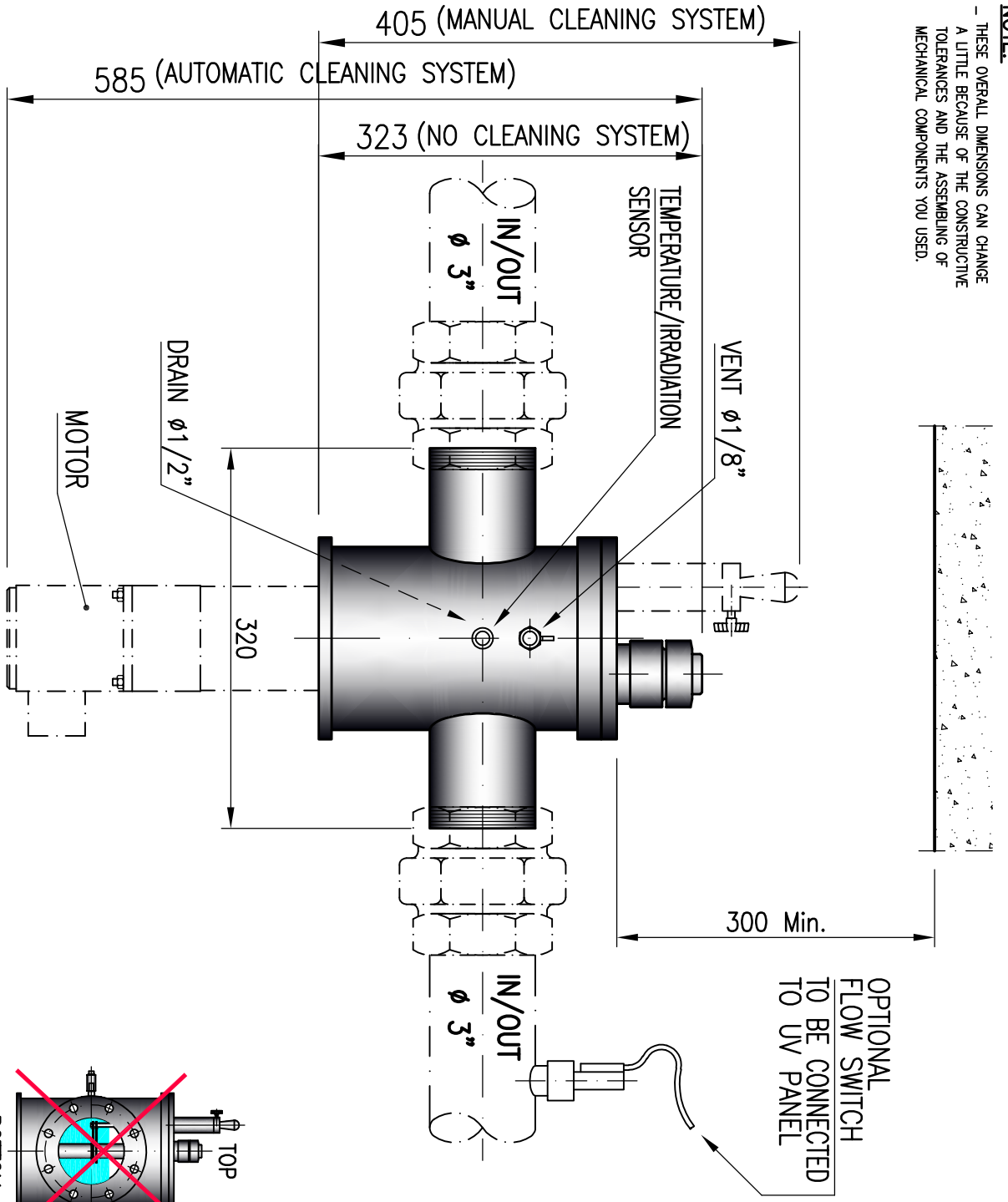

REV.					
A	FIRST ISSUE	24/10/22	SCHENONE	MAZZONE	
	DESCRIPTION	DATE	DREW	APPROVED	

sifo S.r.l. Società Italiana Trattamento Acque
 Via Rivarolo, 61 - 16161 Genova Italy - Tel. 0039-10-7406848 / Fax 0039-10-7406851 email: info@sifotva.com

LA SIFA S.r.l. SI RISERVA I TERMINI DI LEGGE LA PROPRIETÀ DI QUESTO DISEGNO CON DIRITTO DI RIPRODUZIONE O DI RENDIMENTO COMUNE NOVIO A TERA O A DITTE CONCORRENTI SENZA LA SUA AUTORIZZAZIONE SCRITTA

TITLE

SMP 7